

GWS6967

Dual N-Channel MOSFET

General Description

- Advanced **Lateral Power™** technology
- Specially designed for Li-Ion battery packs and battery switch applications
- TSSOP-8 package

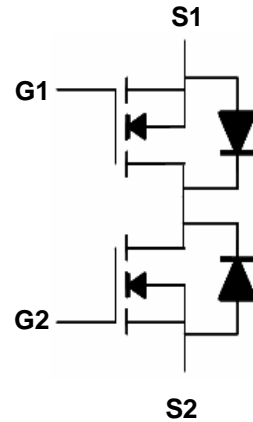

Features

- $r_{DS(ON)} = 30m\Omega$ typical at 4.5 Volts
- $r_{DS(ON)} = 37m\Omega$ typical at 2.7 Volts

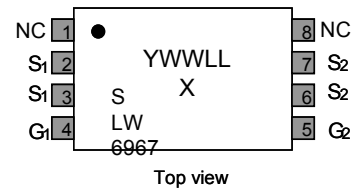
TSSOP-8

YWWLLX = assembly year, week and lot number, full or partial lot

Maximum Ratings and Thermal Characteristics ($T_A=25^\circ\text{C}$ unless otherwise noted)

Parameter	Symbol	Limit	Unit	
Drain-Source Voltage	V_{DS}	20	V	
Gate-Source Voltage	V_{GS}	± 12		
Continuous Drain Current ¹	I_D	5	A	
Pulsed Drain Current ²	I_{DM}	20		
Maximum Power Dissipation ¹	P_D	$T_A=25^\circ\text{C}$	1.5	W
		$T_A=70^\circ\text{C}$	0.96	
Operating Junction and Storage Temperature Range	T_J, T_{stg}	-55 to 150	$^\circ\text{C}$	
Junction-to-Ambient Thermal Resistance ³	R_{thJA}	$t < 10$ sec	83	$^\circ\text{C/W}$
		Steady-State		
Junction-to-Foot (Drain) Thermal Resistance ³	R_{thJF}		70	

Notes: 1. Surface mounted on FR4 board. $t < 10$ s.
 2. Pulse test; pulse width < 300 us, duty cycle $< 2\%$.
 3. Surface mounted on FR4 board.

Electrical Characteristics ($T_J = 25^\circ\text{C}$ unless otherwise noted)

Parameter	Symbol	Test Condition	Min	Typ	Max	Unit
Static¹						
Drain-Source Breakdown Voltage	$V_{(BR)DSS}$	$V_{GS} = 0V, I_D = 250\mu A$	20	-	-	V
Drain-Source On-State Resistance	$R_{DS(on)}$	$V_{GS} = 4.5V, I_D = 2.5A$	-	30	40	m Ω
		$V_{GS} = 2.7V, I_D = 2.5A$	-	37	45	
Gate Threshold Voltage	$V_{GS(th)}$	$V_{DS} = V_{GS}, I_D = 250\mu A$	0.6		-	V
Zero Gate Voltage Drain Current	I_{DSS}	$V_{GS} = 0V, V_{DS} = 20V$	-	-	1	μA
Gate Body Leakage	I_{GSS}	$V_{DS} = 0V, V_{GS} = \pm 12V$	-	-	± 10	μA
Forward Transconductance	g_{fs}	$V_{DS} = 10V, I_D = 2.5A$	-	25	-	S
Dynamic						
Total Gate Charge	Q_g	$V_{DS} = 10V, I_D = 5A, V_{GS} = 4.5V$	-	7		nC
Gate-Source Charge	Q_{gs}		-	1.5	-	
Gate-Drain Charge	Q_{gd}		-	2.3	-	
Turn-On Delay Time	$t_{d(on)}$	$V_{DD} = 10V, I_D = 2.5A, V_{GEN} = 4.5V,$ $R_G = 4.7\text{ ohms}$	-	7		nS
TurnOn Rise Time	t_r		-	33		
Turn-Off Delay Time	$t_{d(off)}$		-	27		
Turn-Off Fall Time	t_f		-	10		
Input Capacitance	C_{iss}	$V_{DS} = 10V, V_{GS} = 0V, f = 1\text{ MHz}$	-	450	-	
Output Capacitance	C_{oss}		-	165	-	
Reverse Transfer Capacitance	C_{riss}		-	125	-	
Source Drain Diode¹						
Diode Forward Voltage	V_{SD}	$I_S = 1.5A, V_{GS} = 0V$	-	0.71	1.2	V

Note: 1.Pulse test; pulse width < 300 us, duty cycle < 2%.

Test Circuit 1: I_{DSS} , Zero Gate Voltage Drain Current

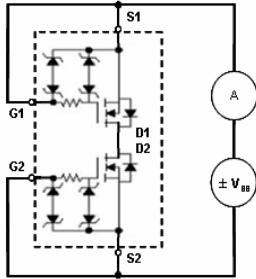

FET (1) I_{DSS} : $V_{S2}=V_{G2}=20V, V_{S1}=V_{G1}=0V$
 FET (2) I_{DSS} : $V_{S1}=V_{G1}=20V, V_{S2}=V_{G2}=0V$

Test Circuit 2: $R_{DS(ON)}$, Drain-to-Source ON State Resistance

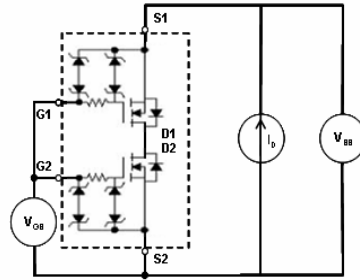

$$FET (1 \text{ or } 2) R_{DS(ON)} = (V_{DS} / I_D) / 2$$

Test Circuit 3: I_{GSS} , Gate Body Leakage

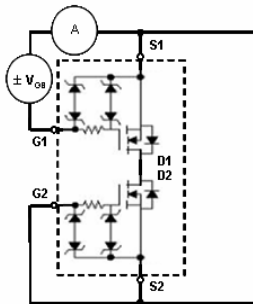

FET (1) I_{GSS} : $V_{GS1} = \pm 12V, V_{S1} = V_{S2} = V_{G2} = 0V$

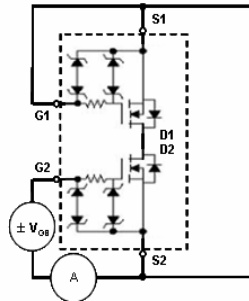

FET (2) I_{GSS} : $V_{GS2} = \pm 12V, V_{S1} = V_{S2} = V_{G1} = 0V$

Test Circuit 4: $V_{GS(th)}$, Gate Body Leakage

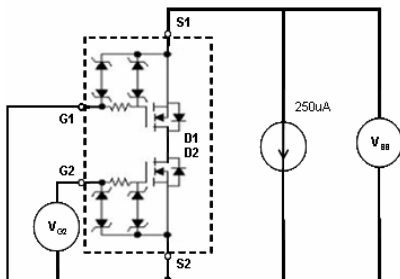

FET (1) $V_{GS(th)1} = V_{SS}$
 Where: $V_{G1}=V_{S2}, V_{S1}=0V, V_{G2}=4.5V, I_{SS}=250uA$

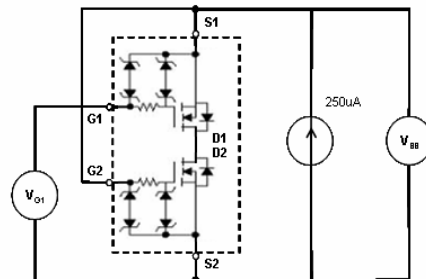

FET (2) $V_{GS(th)2} = V_{SS}$
 Where: $V_{G2}=V_{S2}, V_{S2}=0V, V_{G1}=4.5V, I_{SS}=250uA$

Output Characteristics

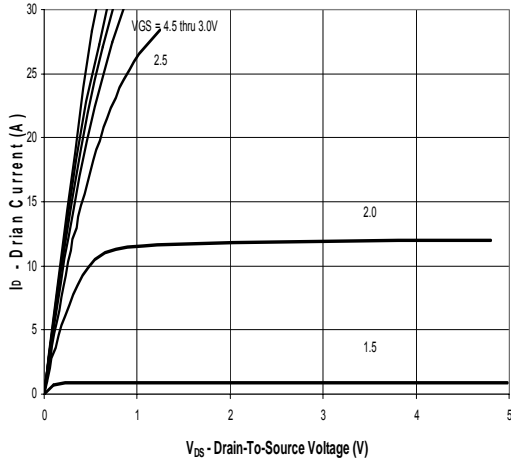

Transfer Characteristics

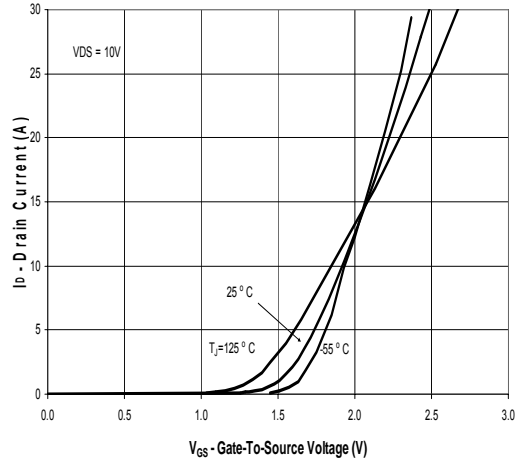

On Resistance Vs. Drain Current

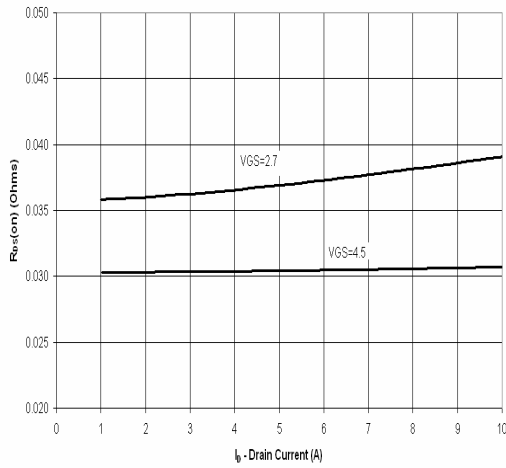

On Resistance Vs. Gate-to-Source Voltage

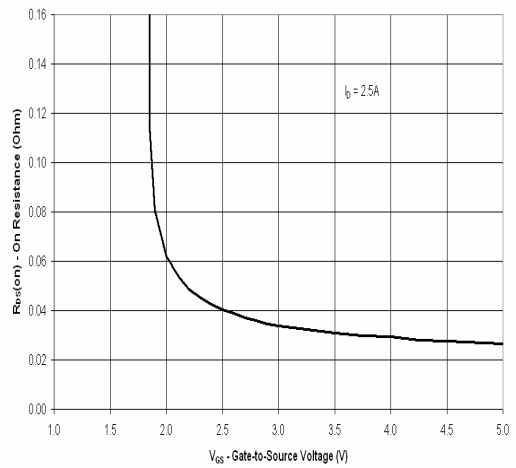

Gate Charge

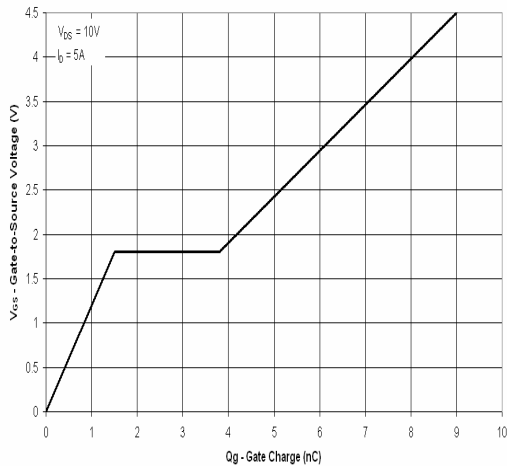

Forward Transconductance Vs. Drain Current

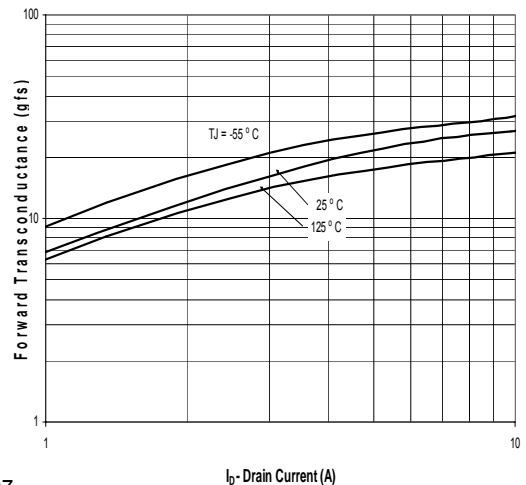

On Resistance Vs. Junction Temperature

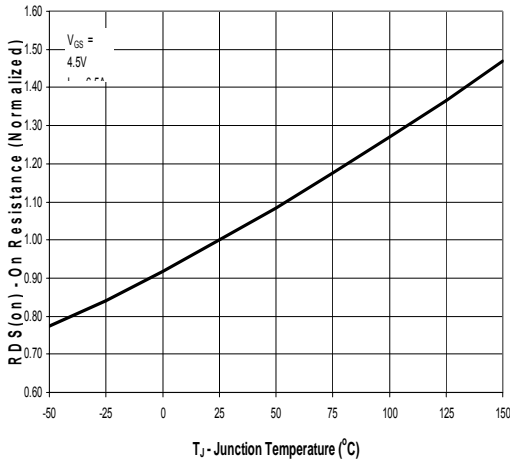

Threshold Voltage Vs. Temperature

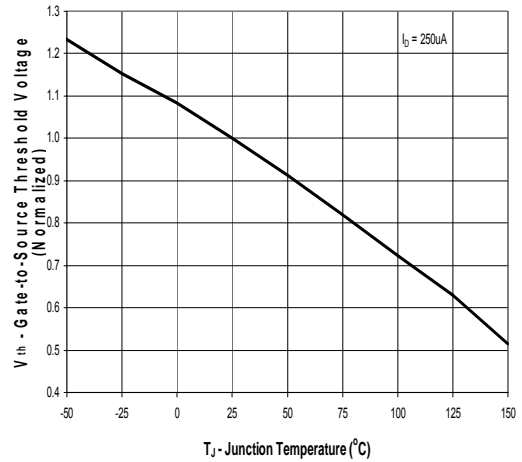

Breakdown Voltage Vs. Junction Temperature

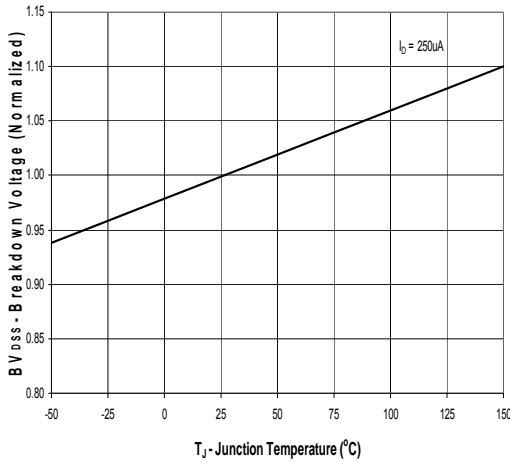

Source Drain Diode Forward Voltage

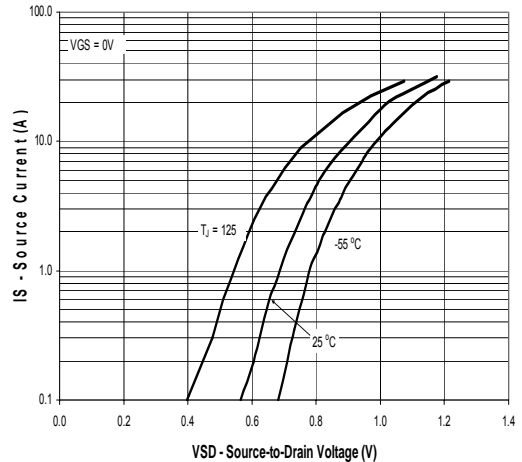

Safe Operating Area, Junction-to-Ambient

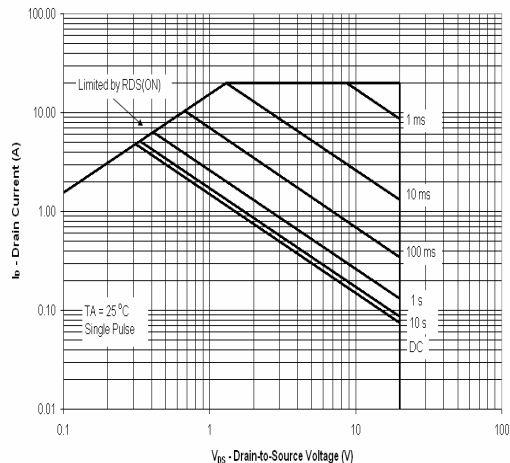

Single Pulse Power

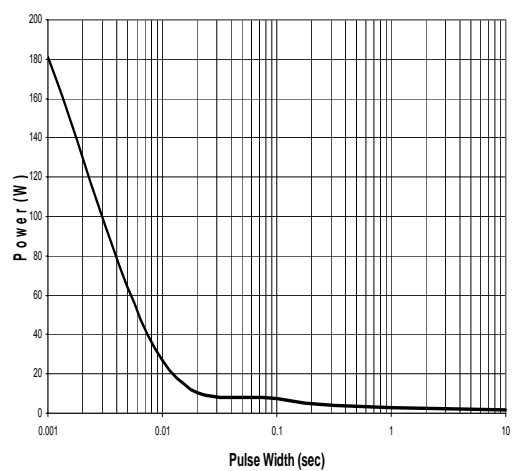

Derating Factor for Forward Bias Safe Operating Area

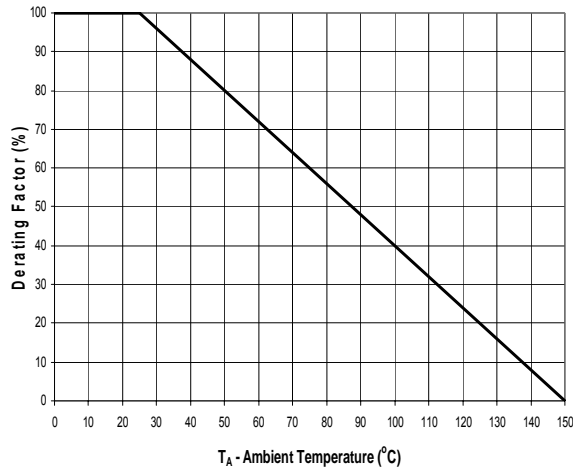

Normalized Transient Thermal Impedance, Junction-to-Ambient

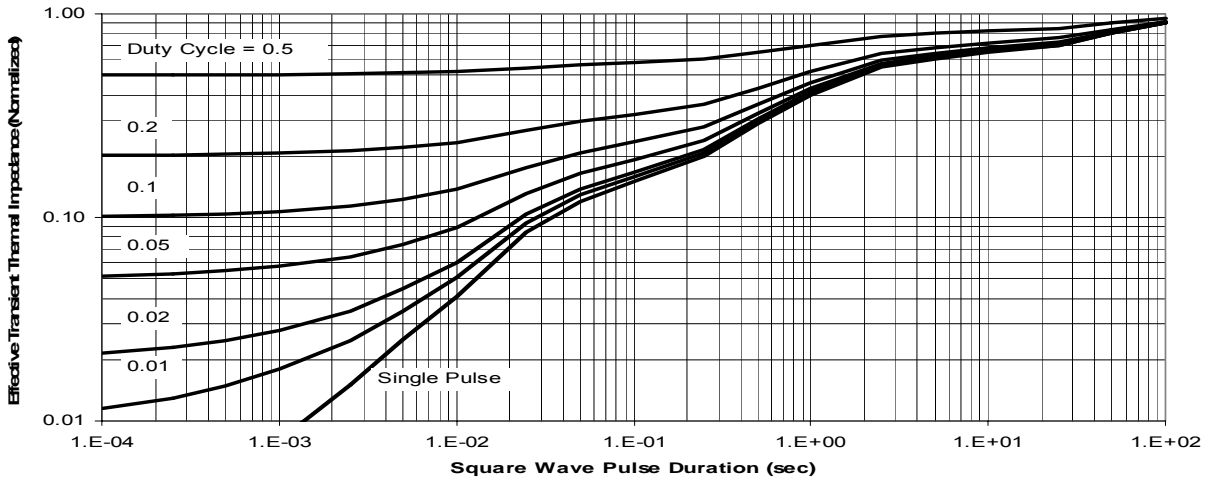

Normalized Transient Thermal Impedance, Junction-to-Foot

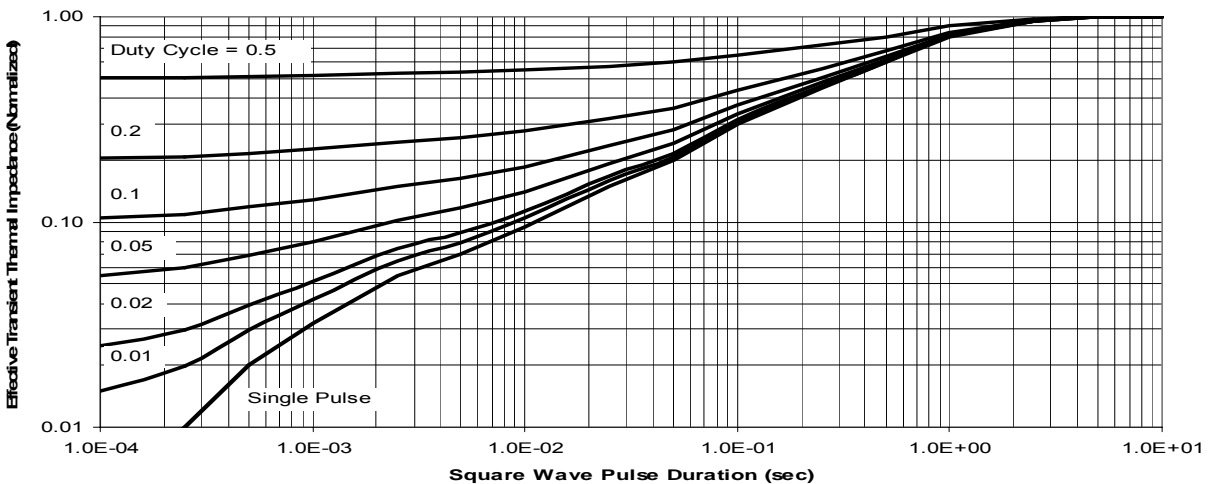

Package Outline

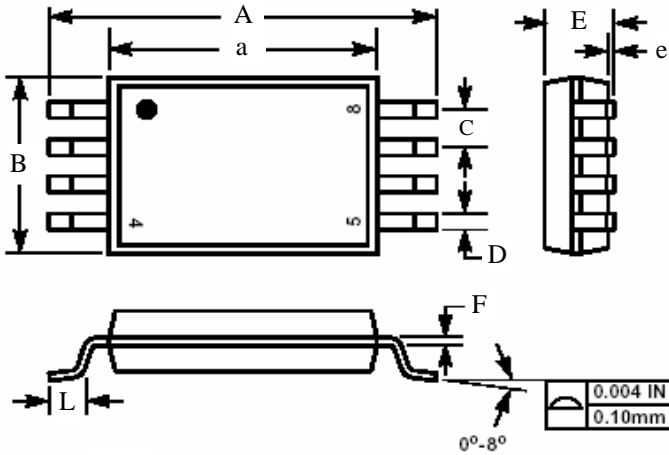

Symbol	inches		Millimeters	
	Min	Max	Min	Max
A	0.244	0.260	6.20	6.60
a	0.170	0.177	4.30	4.50
B	0.114	0.122	2.90	3.10
C	0.025BSC		0.65BSC	
D	0.010	0.012	0.25	0.30
E	0.041	0.047	1.05	1.20
e	0.002	0.006	0.05	0.15
F	0.005		0.127	
L	0.020	0.028	0.50	0.70
REF	MO-153AA			

Mounting Pad Layout

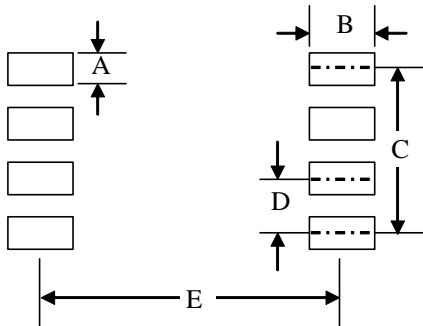

Symbol	inches		Millimeters	
	Min	Max	Min	Max
A	0.01	0.012	0.25	0.30
B	0.020	0.028	0.50	0.70
C	0.077	-	1.95	-
D	0.025	-	0.65	-
E	0.260	-	6.60	-

THERE ARE NO IMPLIED OR EXPRESSED WARRANTIES. ANY AND ALL WARRANTIES OF MERCHANTABILITY, FITNESS FOR A PARTICULAR PURPOSE AND NON-INFRINGEMENT OF THIRD PARTY RIGHTS ARE EXPRESSLY DISCLAIMED.

Reflow Profile Classification

Profile Feature	Sn-Pb Eutectic Assembly	Pb-Free Assembly
Average Ramp-Up Rate ($T_{S_{max}}$ to T_p)	3 °C/second max.	3° C/second max.
Preheat - Temperature Min ($T_{S_{min}}$) - Temperature Max ($T_{S_{max}}$) - Time ($t_{S_{min}}$ to $t_{S_{max}}$)	100 °C 150 °C 60-120 seconds	150 °C 200 °C 60-180 seconds
Time maintained above: - Temperature (T_L) - Time (t_L)	183 °C 60-150 seconds	217 °C 60-150 seconds
Peak/Classification Temperature (T_p)	240°C	260°C
Time within 5 °C of actual Peak Temperature (t_p)	10-30 seconds	20-40 seconds
Ramp-Down Rate	6 °C/second max.	6 °C/second max.
Time 25 °C to Peak Temperature	6 minutes max.	8 minutes max.

Note 1: All temperatures refer to topside of the package, measured on the package body surface.

2: GWS devices can be reflowed a max of 2 times when mounted using our recommended reflow conditions.

3: When repairing after solder reflow, complete with-in 10 seconds for iron temperatures of up to 260°C.

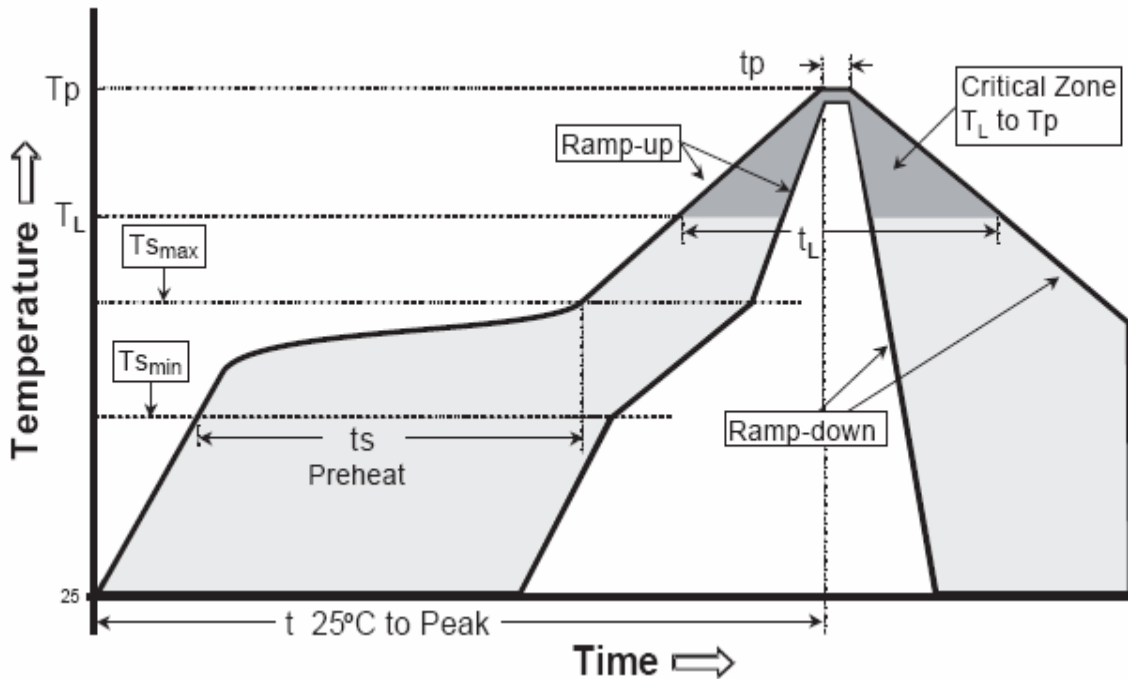

General Precautions and Warnings

- The information in this document is subject to change without notice.
- Before using this document, confirm that this is the latest version.
- No part of this document may be copied or reproduced in any form or by any means without the prior written consent of Great Wall Semiconductor.
- Great Wall Semiconductor assumes to responsibility for any errors that may appear in this document.
- The information contained herein is presented only as a guide for the applications of our products. No responsibility is assumed by Great Wall Semiconductor for any infringements of patents or other rights of the third parties which may result from its use.
- While Great Wall Semiconductor endeavors to enhance the quality, reliability and safety of it's products, customers agree and acknowledge that the possibility of defects thereof cannot be eliminated entirely.
- To minimize the risks of damage to property or injury (including death) to persons arising from defects in Great Wall Semiconductor products, customers must incorporate sufficient safety measures in their design, such as redundancy, fire containment and anti-failure features.
- When the device listed in this document is intended for usage in Lithium Ion Battery charge and discharge control applications, special precautions must be employed by the customer to prevent device damage should a short circuit occur. For example, a PTC Thermistor can be used by the customer to shut off the power supply if a short-circuit occurs. If the power supply is not shut off during a short circuit, a large short circuit current will flow which may cause the device to catch fire or smoke.